



# Embedded Motion Control

Escape Room Challenge

Group 8

# Overview

- Requirements
- Components and Functions
- Measurement plan
- Questions

## Requirements

- Autonomously find the exit
- No wall bumping
- Not tipping over
- Progress each 30 seconds
- Easy to setup software
- Robust functionality



## Specification

- Autonomously find the exit
  - Rear wheel cross the finish line
  - Finish within 5 minutes
  - Finish within 2 trials



## Specification

- No wall bumping
  - Wall robot distance 5 centimeter



## Specification

- Progress each 30 seconds
  - Report status
  - Maintain and switch states to advance strategy plan



## Specification

- Robust functionality
  - Scalable functions
  - Definition of data ownership



## Components and Functions

- User interface
- State machine
- World Model
- Mediator

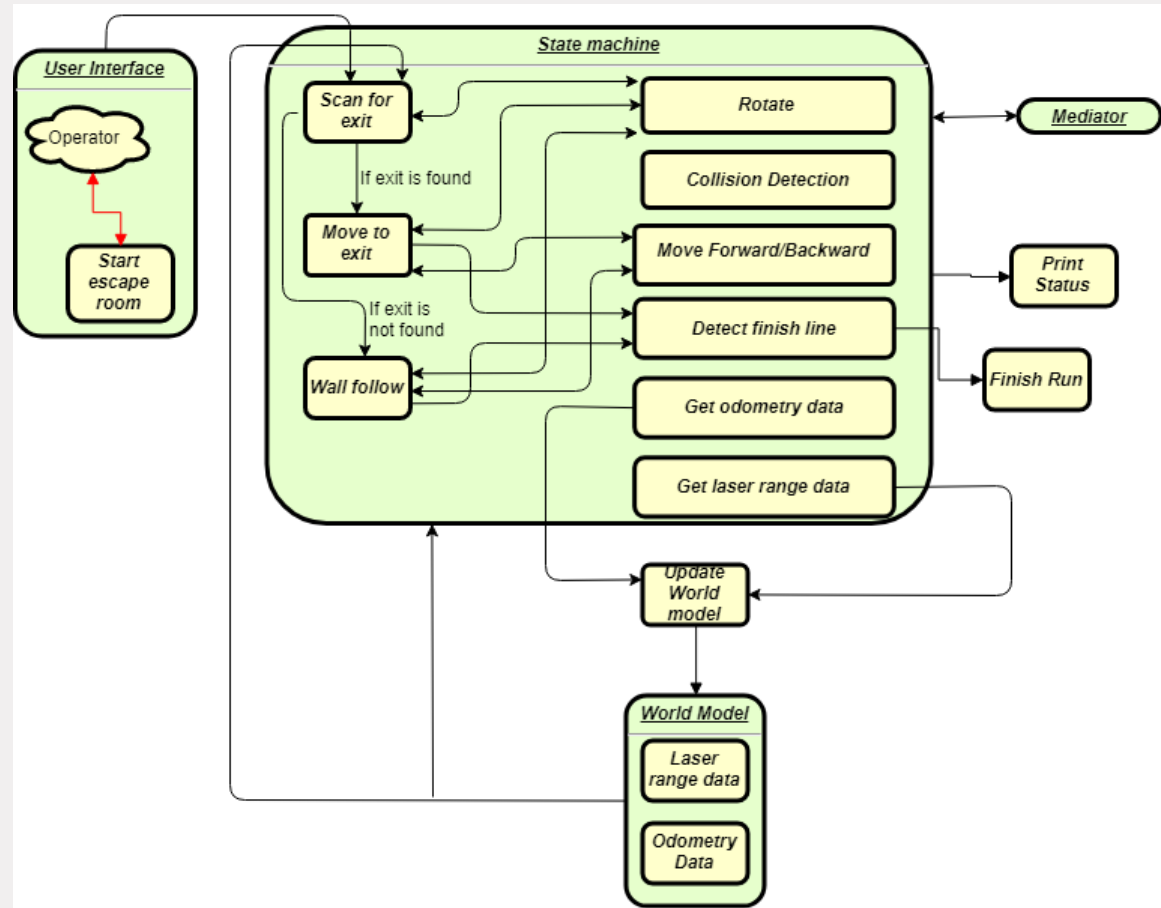



# Components and Functions

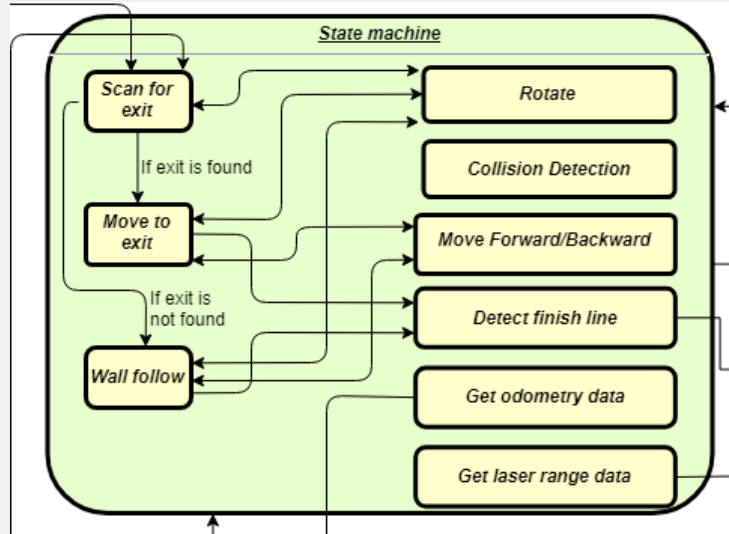

# Summary

- Requirements
- Components and Functions
- Measurement plan
- Questions