

ICMU-Y2 programming and Swerve drive wheel-tuning guide

Swerve-Drive V1.0

commutation over ssi for controlling the swerve-drive platform



Ferry Schoenmakers, Ruud van den Bogaert

Jan 2023

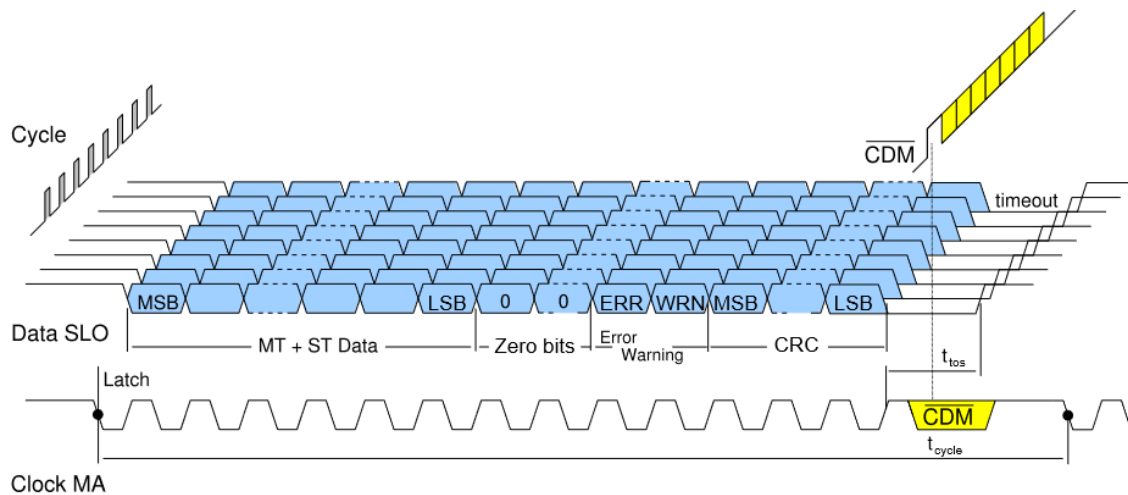

Preface

The Swerve-Drive wheels are equipped with dedicated for this goal designed encoder PCB,s with ICMU brand programmable encoder chips. These encoder chips are freely programmable and can be used as both absolute and incremental encoders with various protocols.

The original ICMU based wheel encoder PCB's are not equipped with an EEPROM. EEPROM makes the PCB more multi-functional for our goal and programmable other software. We have extended the original PCB with this feature. Because this redesign had to have the same form factor, it became a four-layer PCB. The EEPROM is externally programmable via the BISSC protocol over an USB adapter.

For the Swerve drive V1 we used Maxon EtherCAT amplifiers

The texts in blue are links to relevant web documents and software downloads for the tuning procedure.

Contents:

1 Hardware & datasheet links

- 1.1 Abs Enc hardware
- 1.2 Maxon Epos
- 1.3 Drive motor
- 1.4 Rotation motor
- 1.5 Slip rings

2 Connections

2 Software-settings & offset calculations

- 3.1 Relevant software & documents
- 3.2 Settings ICMU Software & EEPROM programming
- 3.3 Nonius Calibration
- 3.4 Switch to SSI
- 3.5 Encoder settings drive motor
- 3.6 Pole pares drive & rotation motor
- 3.7 Calculation example of SSI commutation offset value
- 3.8 SSI offset calculation sheet
- 3.9 SSI offset calculation results

1. Hardware

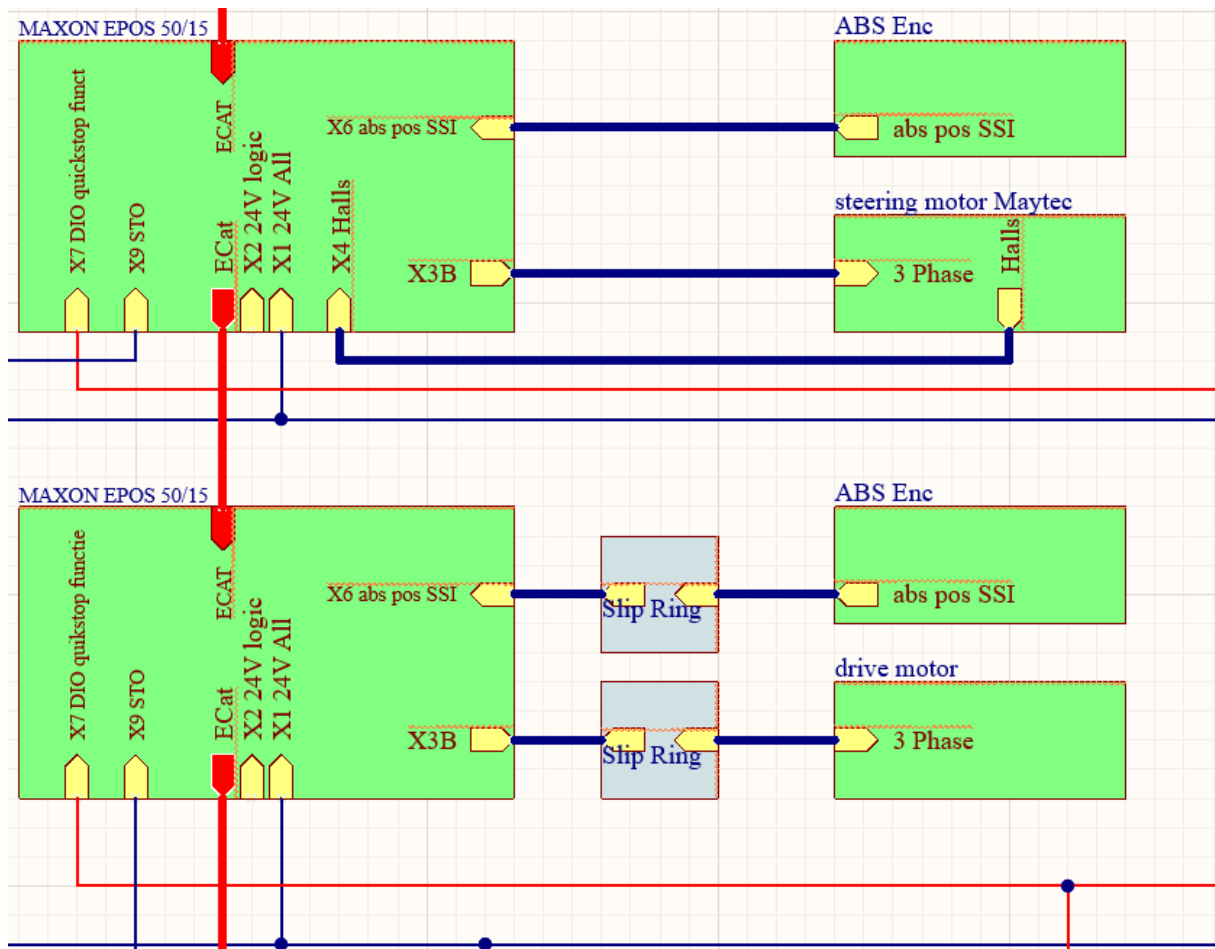

Hardware design wheelsets

1.1 Abs Enc hardware.

PCB V1.0 A KD2207001 (open source hardware by Ketels with EEPROM extension)

Specs components

[iCMU Y2 -\(0x07\) IC-MU DFN16-5X5](#)

https://www.ichaus.de/upload/pdf/MU_datasheet_F2en.pdf

Distributor <https://ave-nl.com/>

[24AA02](#) Microchip EEPROM. Compatible [24LC16BHT-I/MNY.](#)

Distributor [Mouser](#)

[LCT2857IDD-1#PBF](#) RS-422/RS-485 interface chip .

Distributor [Mouser](#)

1.2 Maxon Epos

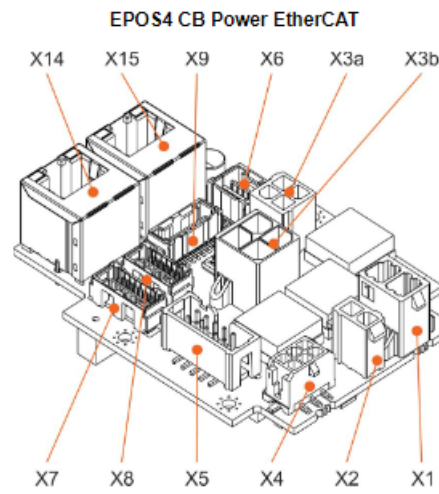

Maxon Epos 50/15 EtherCat

(https://www.maxongroup.com/medias/sys_master/8825356681246.pdf)

1.3 Drive motor, Brand unknown

10 poles pares,

0.1ohm flux-linkage

Induction 150uH



1.4 Steering (rotation) e-scooter motor, brand Maytec

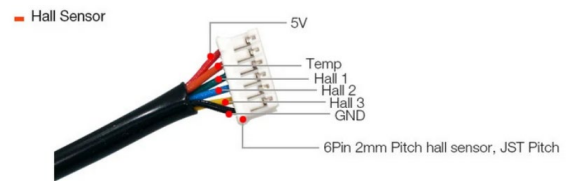

https://www.alibaba.com/product-detail/Maytech-5065-170KV-brushless-outrunner-motor_60732555864.html

1.5 Slip rings

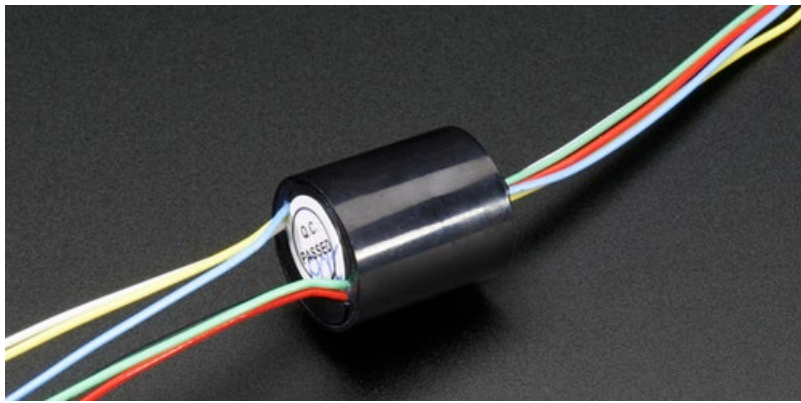

<http://adafru.it/775>

1.6 Programming hardware



https://www.ichaus.de/upload/pdf/MB5U_datasheet_D1en.pdf

3 Connections

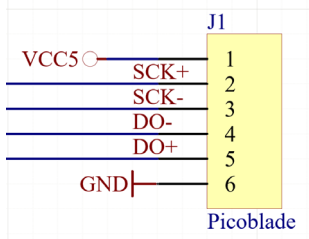

PCB

- 1 VCC
- 2 SCK+
- 3 SCK-
- 4 DO-
- 5 DO+
- 6 GND

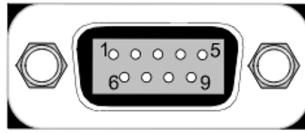

MB5U BISS

- 4 VDD
- 2 MA+
- 3 MA-
- 8 SL-
- 7 SL+
- 6 GND

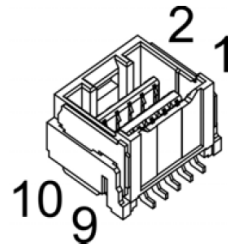

Maxon EPOS

slipring

- 10 V-aux violet red
- 5 Clock SSI grey green
- 6 Clock\ SSI pink violet
- 7 Data SSI blue grey
- 8 Data\ SSI red yellow
- 9 GND black black

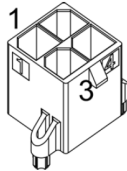

X3b Motor

- | <u>Drive motor</u> | <u>EPOS</u> |
|---|-------------|
| U1 Yellow | 1 |
| U2 Green | 2 |
| U3 Blue | 3 |

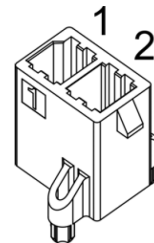

X1 Power Supply

- | <u>Power Supp</u> | <u>EPOS</u> |
|-------------------|------------------------|
| black- | 1 GND |
| black+ | 2 VCC 24V (+10- 50VDC) |

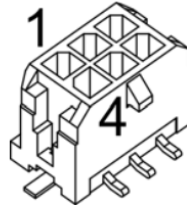
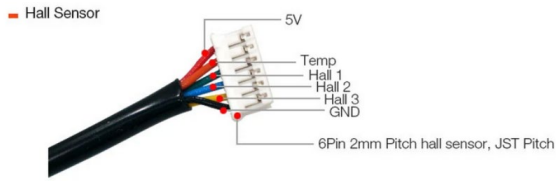

Hall Sensor (only rotation motor)

EPOS

Hal 1

1 Green

Hal 2

2 Brown

Hal3

3 White

5V

4 Grey

GND

5 Yellow

6 Black (shield)

Determination of the direction of rotation. Use this scheme to figure out the right connection. It is possible to use a battery to connect the motors

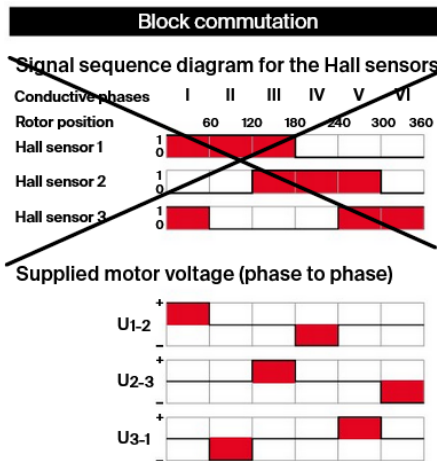

Wheelset 1 Drive

<u>EPOS</u>	<u>Motor-connection cable</u>
1	Black
2	Brown
3	Red

Wheelset 2 Drive

<u>EPOS</u>	<u>Motor-connection cable</u>
1	Black
2	Red
3	Brown

Wheelset 3 Drive

<u>EPOS</u>	<u>Motor-connection cable</u>
1	Red
2	Brown
3	Black

Rotation motors: because the commutation is controlled via hall sensors, the order of the motor does not matter.

3. Software & Tuning

3.1 Relevant software & documents:

-[Drivers for IC-Haus adapters](#)

(https://www.ichaus.de/adapter_drivers)

-ICMU [gui software](#) with RTE

(www.ichaus.de/MU_gui_rte)

-Maxon [Epos Studio IDX](#)

https://www.maxongroup.nl/medias/sys_master/root/8994700001310/EPOS-2-4-IDX-Setup.zip

3.2 Settings ICMU Software:

Connect the ICMU PCB to the MB5U BISS. Port A BISS,

MSB output 18-bit,

SSI Ring Mode Enable.

No zero bits =0.

Make sure the resolution is 19 bit = 524288 bits

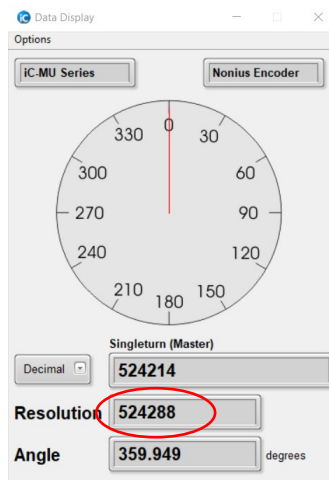
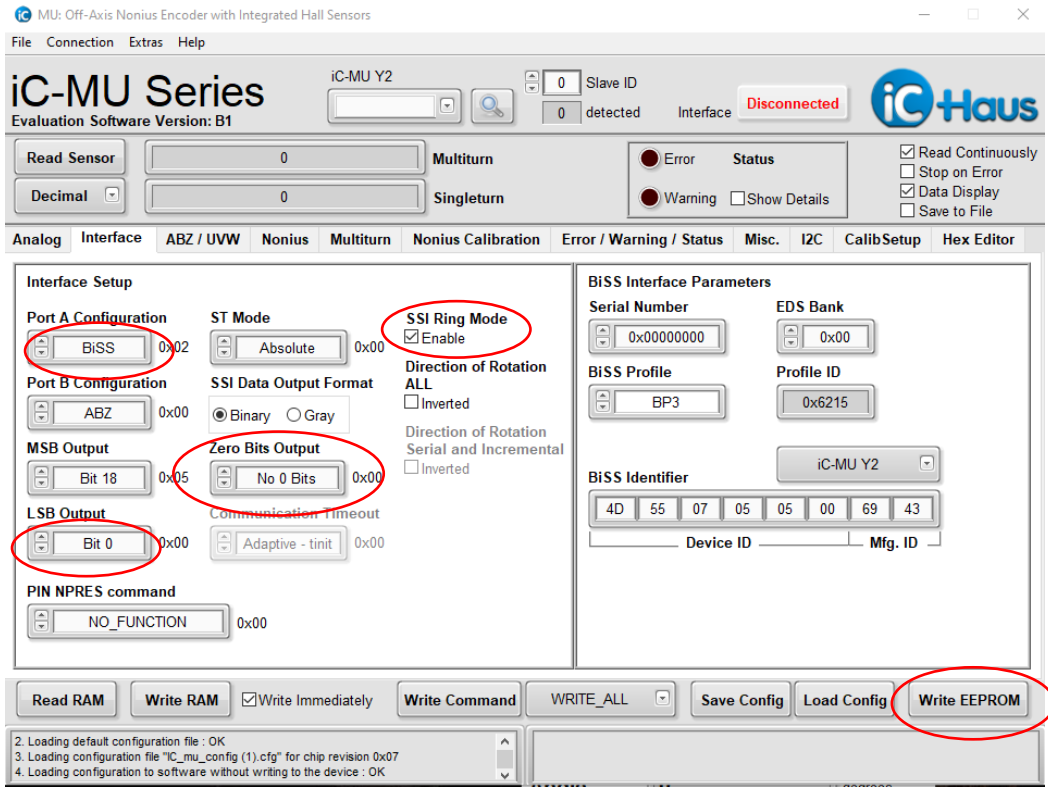

3.3 Nonius Calibration

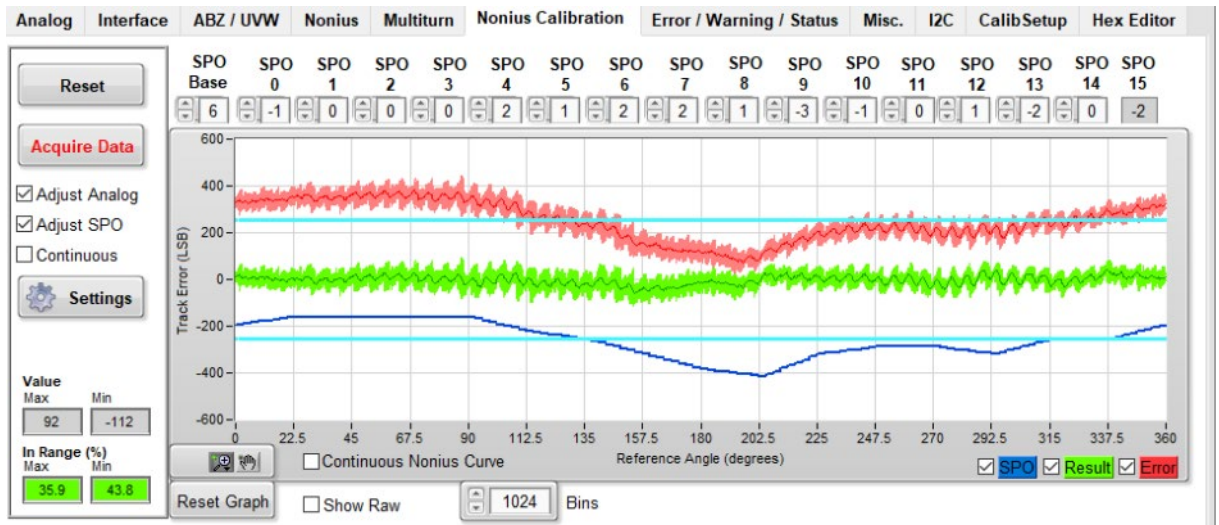

Calibrate the ICMU using the [AN3 appnote calibration and programming](#) step by step:

https://www.ichaus.de/upload/pdf/MU_AN3_appnote_Rotary_calibration_and_programming_D1en.pdf

3.4 Switch to SSI

Switch to SSI with command SWITCH. Disconnect and Connect to enable SSI

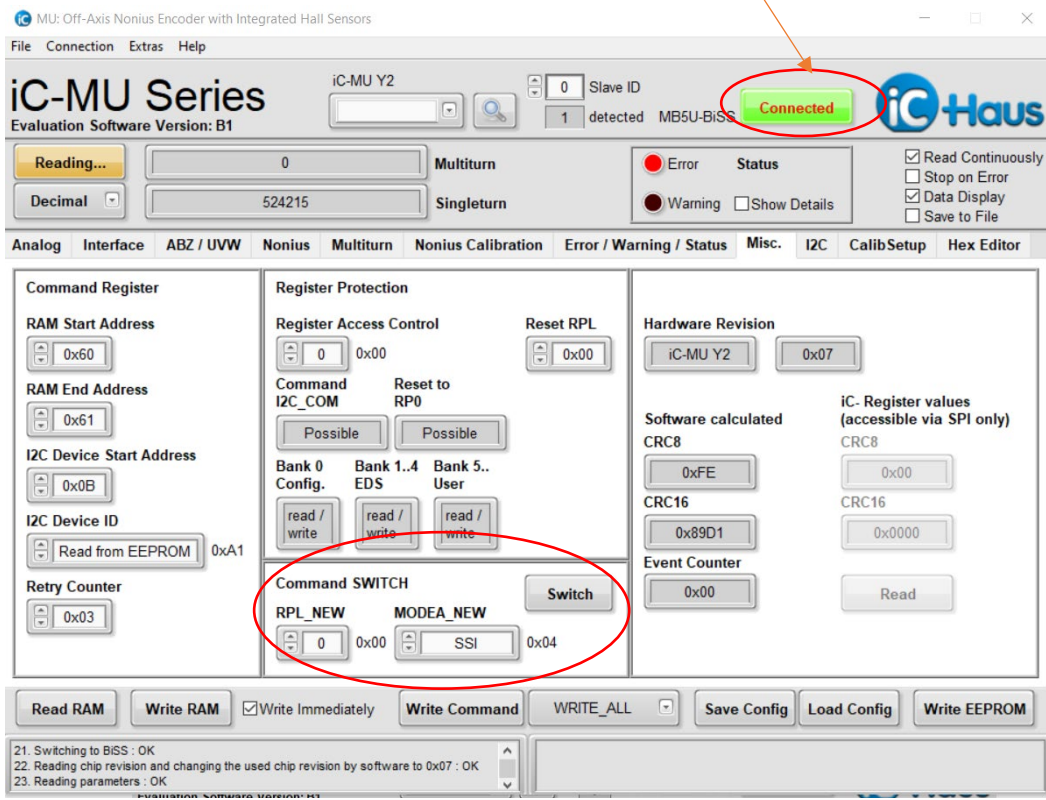

3.4 Pole pares drive motor: 10, pole pares rotation motor: 7

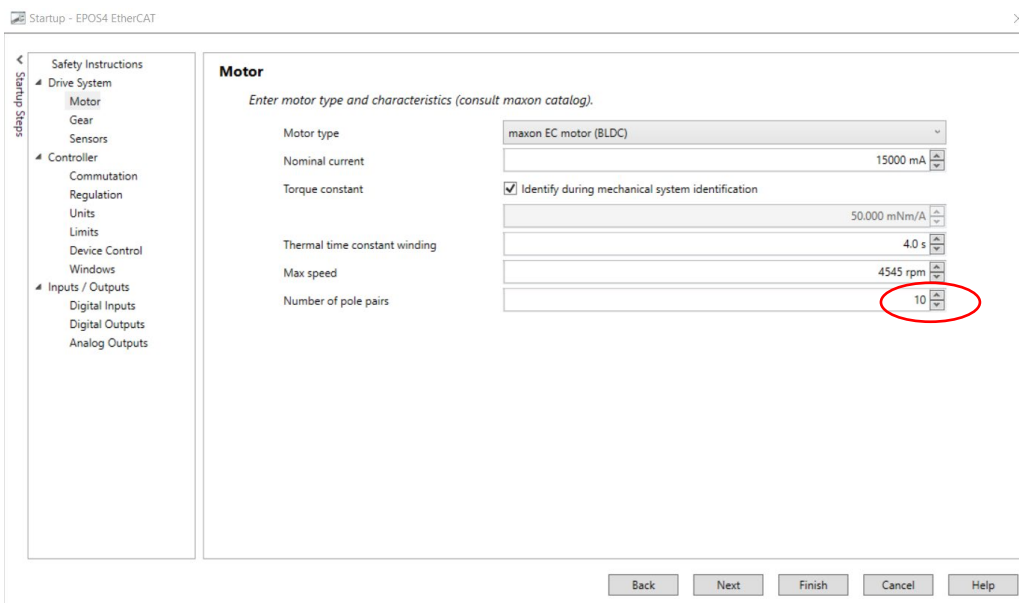

Drive motor : no gear, rotation motor reduction 18 :7

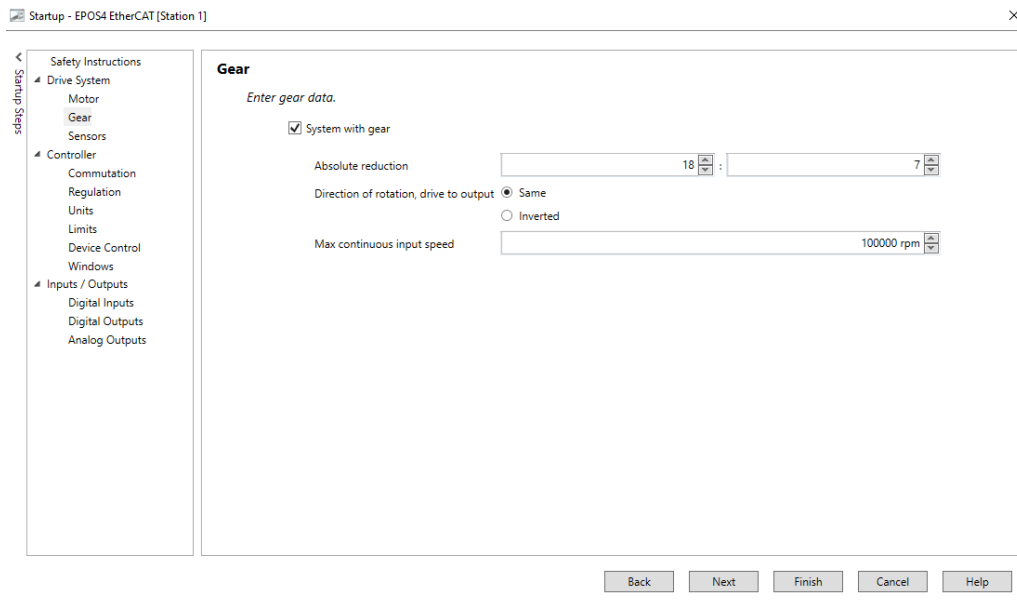

3.5 Encoder settings drive motor. rotation motor + hallsensor -> mounting on shaft

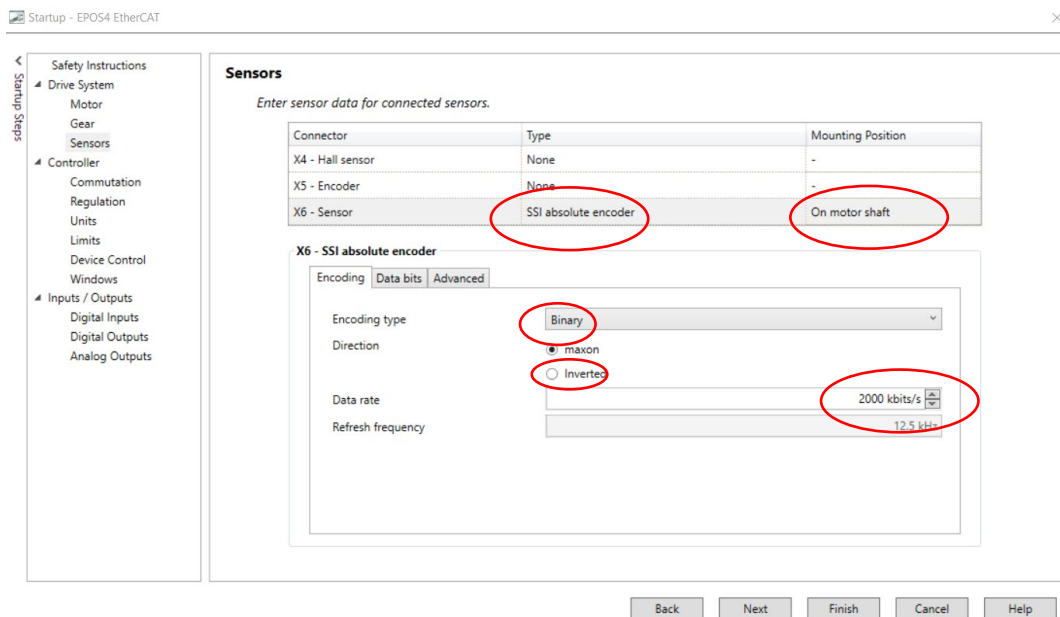

3.6 Encoder settings: Data Bits 19

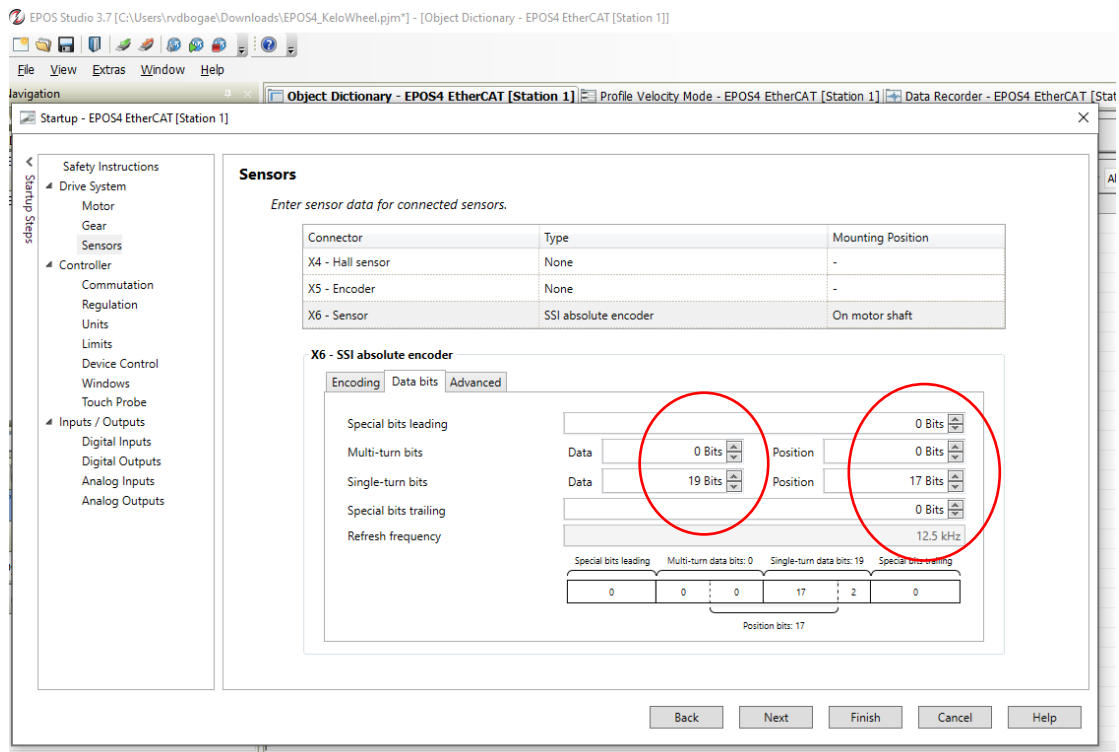

Commutation rotation:

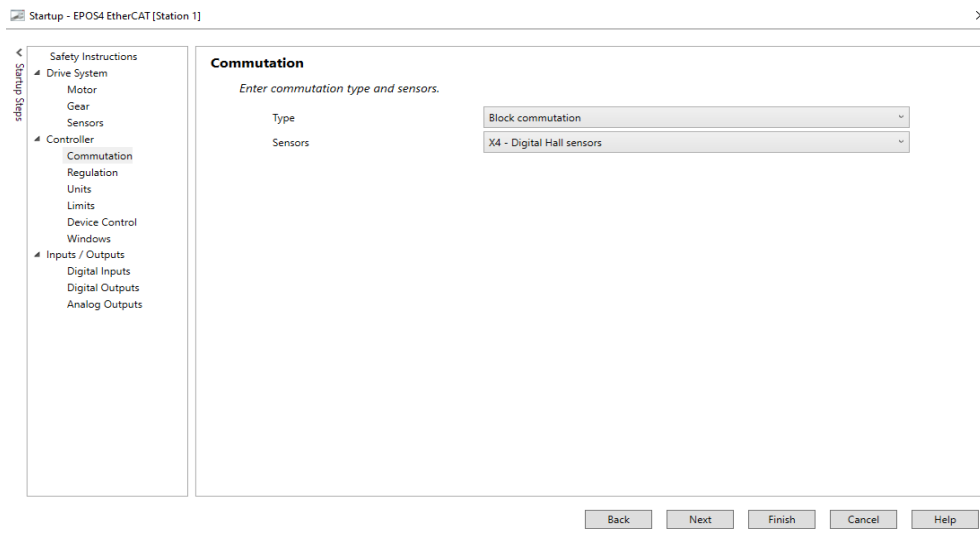

steps drive

- ^ Safety Instructions
- ▲ Drive System
 - Motor
 - Gear
 - Sensors
- ▲ Controller
 - Commutation
 - Regulation
 - Units
 - Limits
 - Device Control
 - Windows
 - Touch Probe
- ▲ Inputs / Outputs
 - Digital Inputs
 - Digital Outputs
 - Analog Inputs
 - Analog Outputs

Commutation

Enter commutation type and sensors.

Type	Sinusoidal commutation
Sensors	X6 - SSI absolute encoder
SSI commutation offset value	43690 inc

Back Next Finish Cancel Help

3.7 Calculation of SSI commutation offset value:

Application notes collection, follow the steps chapter [8 page 131-135](#):

Calculation offset flow chart:

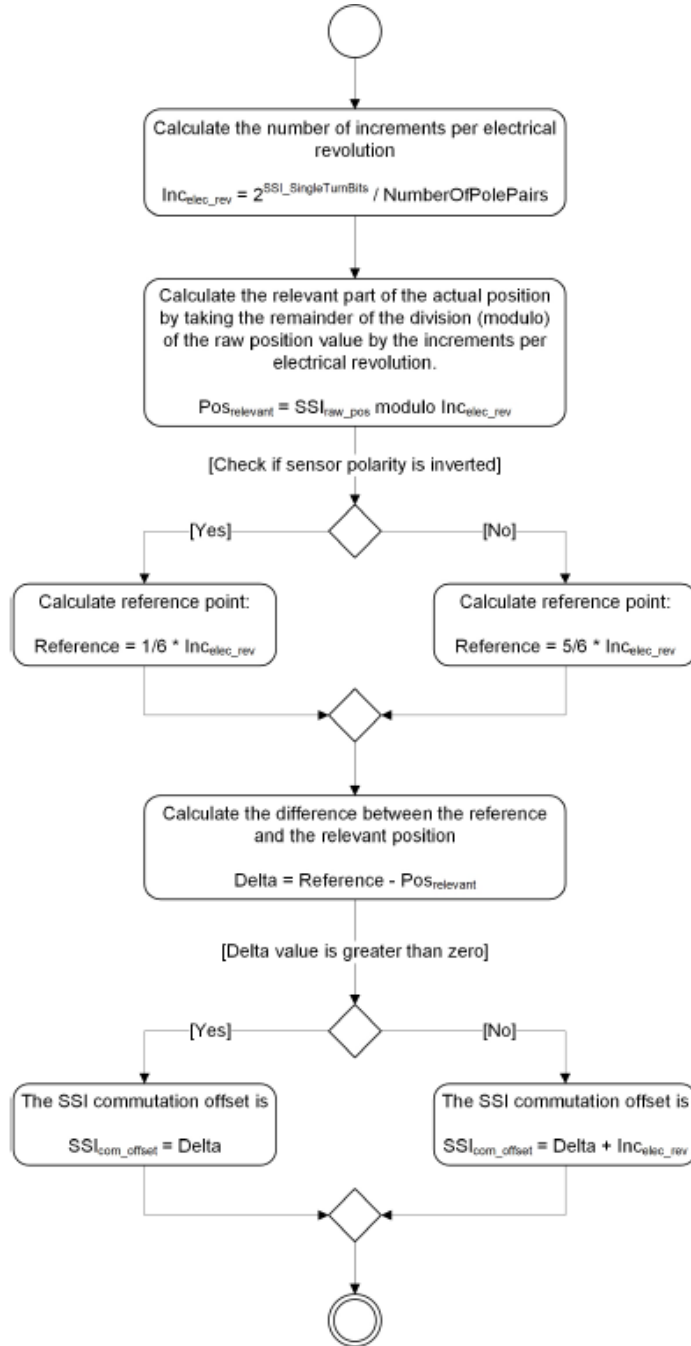

Figure 8-133 Adjustment of SSI commutation offset value | Determine SSI commutation offset value

3.8 Exel calculation sheet

Enc res	524288			Inverted	Non Inverted (Maxon)			Bits	Enc cnt	
N Pole Pairs	10		<u>n incs per electr. Rev</u>	52428,8	52428,8			1	2	
Enc pos test	1956		<u>pos-relevant</u>	1956	1956			2	4	
			<u>reference-point</u>	8738,133333	43690,66667			3	8	
			<u>Delta</u>	6782,133333	41734,66667			4	16	
			<u>Delta + 1N</u>	59210,93333	94163,46667			5	32	
								6	64	
								7	128	
								8	256	
								9	512	
								10	1024	
								11	2048	
								12	4096	
								13	8192	
								14	16384	
								15	32768	
								16	65536	
								17	131072	
								18	262144	
								19	524288	
										1456,356

3.9 Offset calculation results

Wheelset 1 drive wheel

SSI commutation offset value : **43690**

Wheelset 2 drive wheel

SSI commutation offset value : **866**

Wheelset 3

SSI commutation offset value : **14895**