

Block diagram_3 ELEKTRONICS FAST

Power Distribution

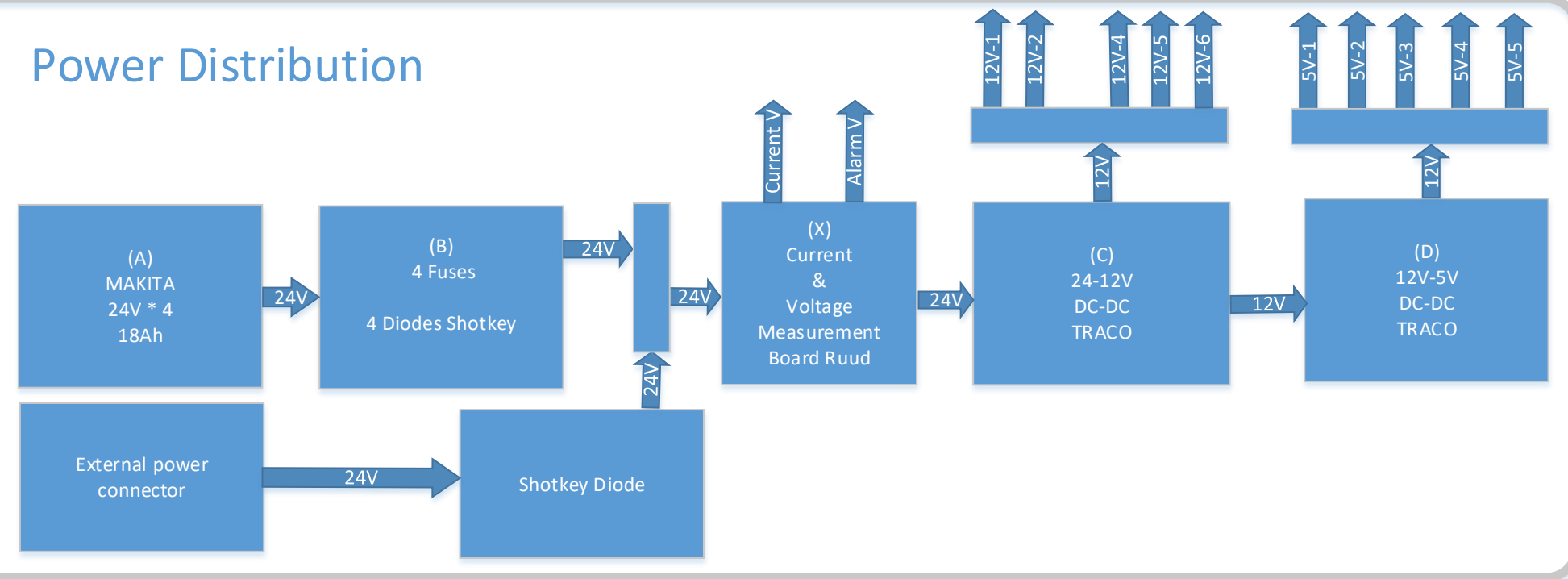

Sound & Touch

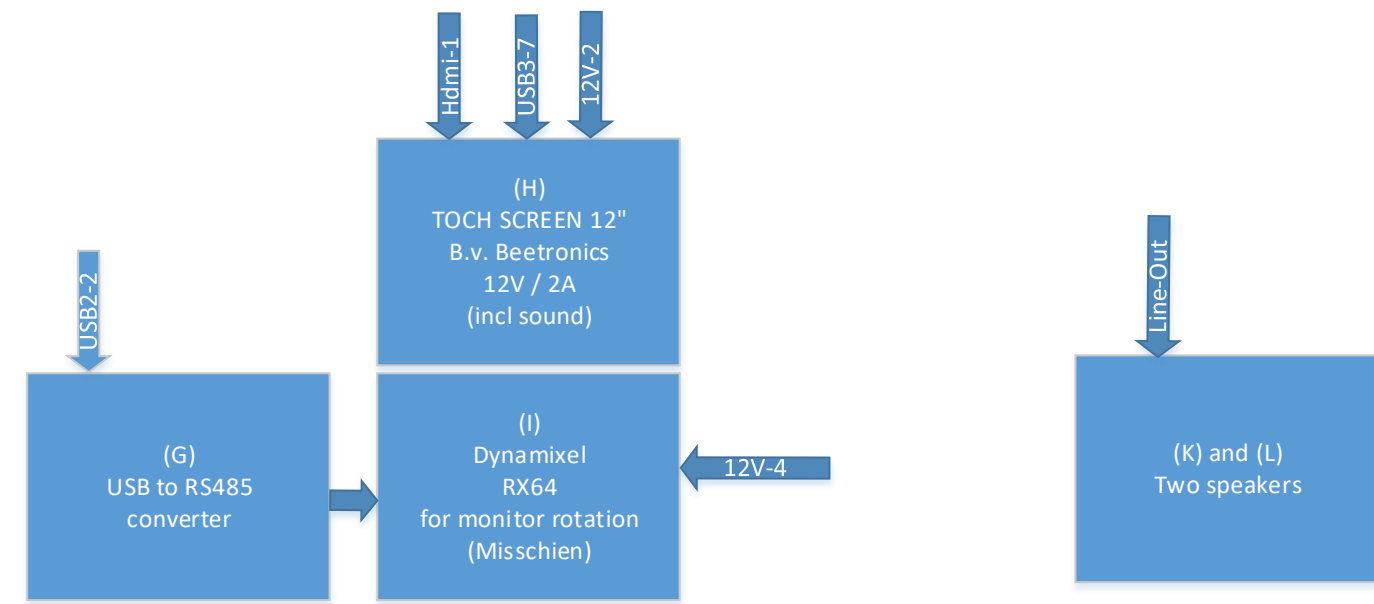

Computers

← used port
← free port

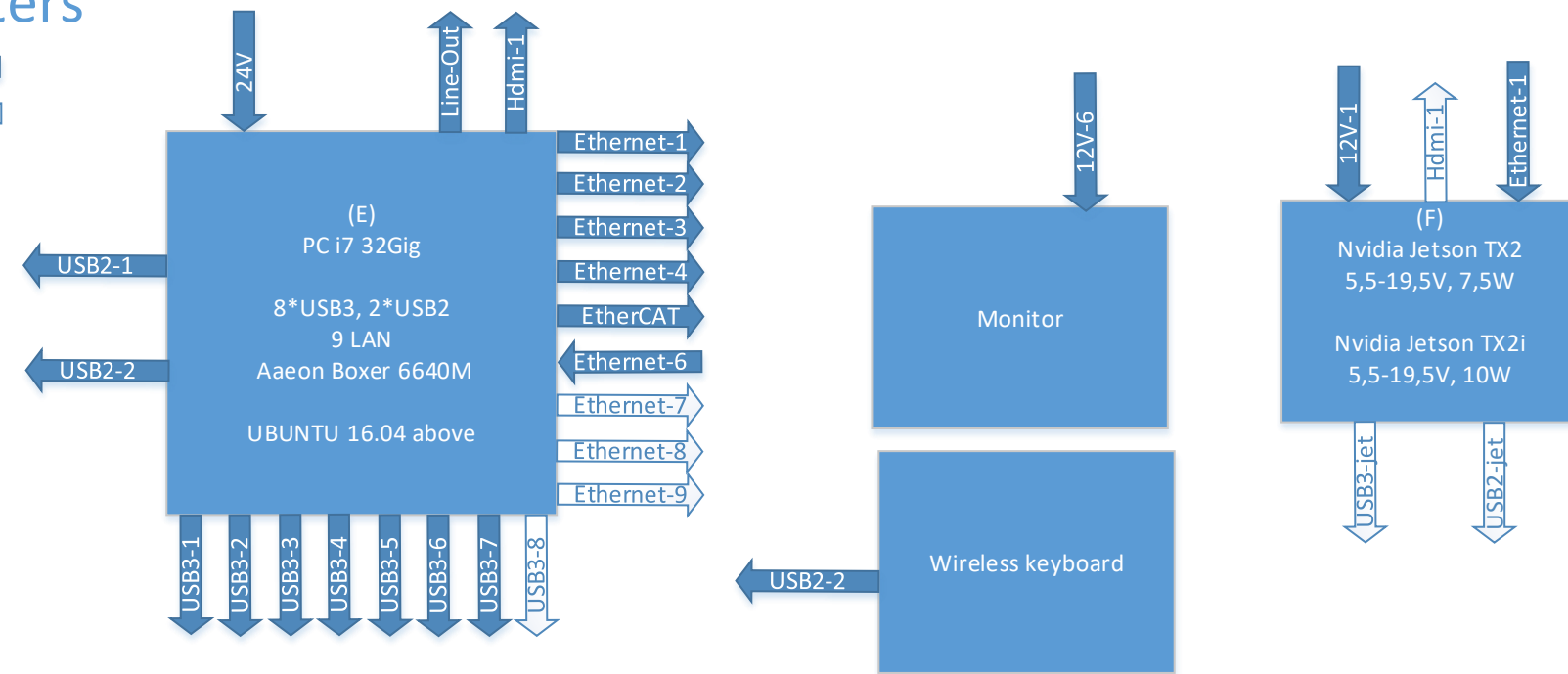

Conectivity

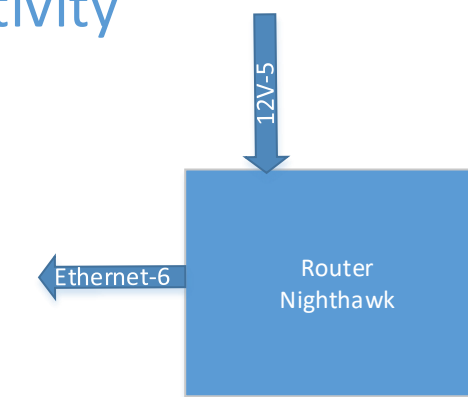

Sensors

